

DH-SD6AE230F-HNI

2MP 30x Starlight IR PTZ Network Camera



- 1/1.9" 2Megapixel Exmor CMOS
- Powerful 30x optical zoom
- Starlight technology
- Max. 30fps@1080P and 60fps@720P
- Support Hi-PoE
- IR distance up to 200m
- IP67 , IK10



System Overview

Featuring with powerful optical zoom and accurate pan/tilt/zoom performance, this series provides an all-in-one solution for capturing long distance video surveillance for outdoor applications. Together with its infrared illumination and Starlight Technology, the camera is the perfect solution for dark, lowlight applications. The series combines a day/night mechanical IR cut filter for the highest image quality for variable lighting conditions during the day and True WDR for applications with direct sunlight or glare.

Functions

Starlight Technology

Featuring Dahua's Starlight Technology, this camera is ideal for applications with challenging lighting conditions. Its low-light performance delivers usable video with minimal ambient light. Even in extreme low-light conditions, Starlight Technology is capable of delivering color images in near complete darkness (0.002 lux).

Wide Dynamic Range

Embedded with industry leading wide dynamic range (WDR) technology, vivid pictures are achieved even in the most intense contrast lighting conditions. For applications with both bright and low lighting conditions that change quickly, True WDR (120dB) optimizes both the bright and dark areas of a scene at the same time to provide usable video.

Smart H.264+

Delivering high quality video without straining the network, Smart H.264+ is the optimized implementation of H.264. The Smart H.264+ encoding platform includes a scene adaptive encoding strategy, dynamic GOP, dynamic ROI, flexible multi-frame reference structure and intelligent noise reduction, providing a savings of up to 70% of bandwidth and storage when compared with standard H.264.

Environmental

With a temperature range of -40 °C to +70 °C (-40 °F to +158 °F), the camera is designed for extreme temperature environments. The camera complies an IK10 impact rating making it capable of withstanding the equivalent of 55 kg (120 lbs) of force. Subjected and certified to rigorous dust and water immersion tests, the IP67 rating makes it suitable for demanding outdoor applications.

Protection

Supporting $\pm 25\%$ input voltage tolerance, this camera suits even the most unstable conditions for outdoor applications. Its 8KV lightning rating provides protection against the camera and its structure from the effects of lightning.

Interoperability

The camera conforms to the ONVIF (Open Network Video Interface Forum) and PSIA (Physical Security Interoperability Alliance) specifications, ensuring interoperability between network video products regardless of manufacturer.

Technical Specification

Camera

Image Sensor	1/1.9" Exmor CMOS
Effective Pixels	1920(H) x 1080(V), 2 Megapixels
RAM/ROM	1024M/64M
Scanning System	Progressive
Minimum Illumination	Color: 0.002Lux@F1.5; 0Lux@1.5 (IR on)
S/N Ratio	More than 56dB
IR Distance	Distance up to 200m (656ft)
IR On/Off Control	Auto/Manual
IR LEDs	10

Lens

Focal Length	6mm~180mm
Max. Aperture	F1.5~ F4.3
Angle of View	H: 61.2° ~ 2.1°
Optical Zoom	30x
Focus Control	Auto/Manual
Close Focus Distance	100mm~ 1000mm

PTZ

Pan/Tilt Range	Pan: 0° ~ 360° endless; Tilt: -20° ~ 90°, auto flip 180°
Manual Control Speed	Pan: 0.1° ~ 200° /s; Tilt: 0.1° ~ 120° /s
Preset Speed	Pan: 240° /s; Tilt: 200° /s
Presets	300
PTZ Mode	5 Pattern, 8 Tour, Auto Pan ,Auto Scan
Speed Setup	Human-oriented focal Length/ speed adaptation
Power up Action	Auto restore to previous PTZ and lens status after power failure
Idle Motion	Activate Preset/ Scan/ Tour/ Pattern if there is no command in the specified period
Protocol	DH-SD, Pelco-P/D (Auto recognition)

Intelligence

Auto Tracking	Support
IVS (optional)	Tripwire, Intrusion, Abandoned/Missing, Face Detection

Video

Compression	H.264+/H.264 / MJPEG	
Streaming Capability	3 Streams	
Resolution	1080P(1920x1080)/720P(1280x720)/D1(704x576/704x480)/CIF(352x288/352x240)	
Frame Rate	Main stream	1080P/D1(1~25/30fps), 720P(1~50/60fps)
	Sub stream1	D1/CIF(1 ~ 25/30fps)
	Sub stream2	720P/D1/ CIF (1 ~ 25/30fps)

Bit Rate Control	CBR/VBR
Bit Rate	H.264+/H.264:56K~8192Kbps, MJPEG: 56K ~ 20480Kbps
Day/Night	Auto(ICR) / Color / B/W
Backlight Compensation	BLC / HLC / WDR(120dB)
White Balance	Auto,ATW,Indoor,Outdoor,Manual
Gain Control	Auto / Manual
Noise Reduction	Ultra DNR (2D/3D)
Motion Detetion	Support
Region of Interest	Support
Electronic Image Stabilization (EIS)	Support
Defog	Support
Digital Zoom	16x
Flip	180°
Privacy Masking	Up to 24 areas

Audio

Compression	G.711a/G.711u(32kbps)/PCM(128kbps)
-------------	------------------------------------

Network

Ethernet	RJ-45 (10/100Base-T)
Protocol	IPv4/IPv6,HTTP,HTTPS,SSL,TCP/IP, UDP,UPnP, ICMP,IGMP,SNMP,RTSP,RTP, SMTP, NTP,DHCP, DNS,PPPOE,DDNS,FTP, IP Filter,QoS,Bonjour,802.1x
Interoperability	ONVIF, PSIA, CGI
Streaming Method	Unicast / Multicast
Max. User Access	20 users
Edge Storage	NAS (Network Attached Storage),Local PC for instant recording, 128GB
Web Viewer	IE10/Google/Firefox/Safari...
Management Software	Smart PSS, DSS
Smart Phone	iPhone, iPad, Android, Windows Phone

Certifications

Certifications	CE: EN55032/EN55024/EN50130-4 FCC: Part15 subpartB,ANSI C63.4- 2014 UL: UL60950-1+CAN/CSA C22.2.No.60950-1
----------------	--

Interface

Video Interface	1
Audio Interface	1/1
RS485	1
Alarm	7/2

Electrical

Power Supply	AC24V/3A(±25%), Hi-PoE
Power Consumption	24W, 38W (IR on)

Environmental

Operating Conditions	-40°C ~ 70°C (-40°F ~ +158°F) / Less than 90% RH
Ingress Protection	IP67
Vandal Resistance	IK10

Construction

Casing	Metal
Dimensions	Ø240(mm) x 382 (mm)
Net Weight	6.75kg(14.88lb)
Gross Weight	10.1kg(22.27lb)

Ordering Information

Type	Part Number	Description
2MP PTZ Camera	DH-SD6AE230F-HNI	2MP 30x Starlight IR PTZ Network Camera, WDR, PAL
	DH-SD6AE230FN-HNI	2MP 30x Starlight IR PTZ Network Camera, WDR, NTSC
	SD6AE230F-HNI	2MP 30x Starlight IR PTZ Network Camera, WDR, PAL
	SD6AE230FN-HNI	2MP 30x Starlight IR PTZ Network Camera, WDR, NTSC
Accessories	PFB303W	Wall Mount
	PFA111	Mount Adapter
	AC24V/3A	Power Supply
	PFA140	Power box
	PFB300C	Ceiling Mount
	PFA120	Junction Box
	PFA150	Pole Mount
	PFA151	Corner Mount
PFB303S	Parapet mount	

Accessories

Included:



PFB303W
Wall Mount



PFA111
Mount Adapter



AC24V/3A
Power Supply

Optional:



PFA140
Power box



PFB300C
Ceiling Mount



PFA120
Junction Box



PFA150
Pole Mount

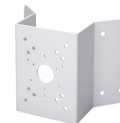

PFA151
Corner Mount



PFB303S
Parapet Mount

Ceiling Mount	Junction Mount
PFA111 + PFB300C	PFA111 + PFB303W + PFA120
Power Box Mount	Pole Mount
PFA111 + PFB303W + PFA140	PFA111 + PFB303W + PFA150
Corner Mount	Parapet Mount
PFA111 + PFB303W + PFA151	PFA111+ PFB303S

Dimensions (mm)

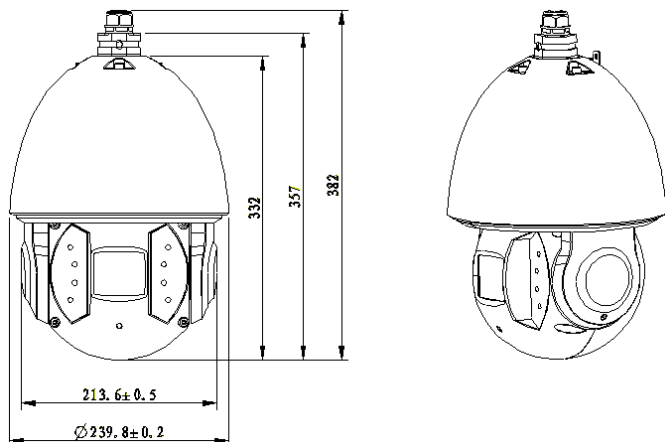

Dahua Technology Co., Ltd. 1187BinAn Road, Binjiang District, Hangzhou, China
Tel: 66956096-09126017817-09107616575
email:imensazaa@gmail.com
www.irandahua.com